

A construction site background showing workers in blue jeans and hard hats. In the foreground, there is a large, dark metal rebar grid structure with yellow safety ribbons tied to it. A large, cylindrical concrete component is being lifted or moved in the middle ground.

# PCI Journal

SEPTEMBER—OCTOBER 2016  
VOLUME 61, NUMBER 5

Precast/Prestressed Concrete Institute

## Fiber-reinforced polymers

**29**

Use of CFRP in  
bridge applications

**37**

CFRP grid  
for precast  
concrete piles

**49**

Behavior of  
flanges reinforced  
with CFRP



Kenichi Ushijima, Tsuyoshi Enomoto, Noriaki Kose, and Yoshiaki Yamamoto

# Field deployment of carbon-fiber-reinforced polymer in bridge applications

**O**n harsh climates, corrosion of steel reinforcement and prestressing strands creates concerns for safety, long-term durability, and the need for rehabilitation work. Carbon-fiber-reinforced polymer (CFRP) materials are an alternative because of their noncorrosive nature, durability, high tensile strength, and light weight. CFRP has been used in cold regions, where deicing chemicals applied during the winter season can corrode steel reinforcement and strands in bridge superstructure components, including the beams and deck.

Bridge Street Bridge, the first bridge in the United States to use CFRP in the form of carbon-fiber-composite cable (CFCC), was built in Michigan in 2001. Since then, extensive experimental, analytical, and numerical research investigations have been conducted by the researchers. Initially, CFCC was rarely used in highway bridge construction. Since 2011, however, the use of CFCC has been increasing in highway bridge applications. Eighteen completed projects have used CFCC in the United States, and there are three future projects planned that will use CFCC.

In Michigan, three highway bridges were built with CFCC-prestressed concrete beams in 2013, 2014, and 2015, and four side-by-side box-beam bridges were transversely posttensioned with unbonded CFCC in 2011, 2012, 2014, and 2015. In Maine, CFCCs were transversely posttensioned for the Little Pond Bridge in Fryeburg in 2012 and were longitudinally pretensioned for the Kittery overpass bridge in 2014. In Kentucky, CFCCs were used for a hybrid I-girder in the Taylor County bridge. In Virginia, CFCCs were used for a bulb-tee girder in the Route 49 bridge over Aaron's Creek. In North Carolina, a research project was conducted for the use of CFCC in a cored deck slab. In Florida, CFCCs were used in the double-tee beams of a pedestrian bridge at the University of Miami.

- Carbon-fiber-reinforced polymer (CFRP) materials are an alternative to steel reinforcement and prestressing strands in harsh climates because of their noncorrosive nature, durability, high tensile strength, and light weight.
- CFRP has been used in bridges in the form of carbon-fiber-composite cable (CFCC). CFCC's unique performance influences the design requirements of members with CFCC reinforcement.
- Design specifications that are under development will help highway transportation agencies make decisions about the use of CFRP for prestressed concrete bridge beams.

The other major use of CFRP is for coastal areas, where seawater and wind can corrode steel reinforcement and strands in substructure elements, such as concrete piles. The Florida Department of Transportation (FDOT) conducted a research project in which five 24 in. (610 mm) square piles were fabricated for tensile testing and for driving tests in the field. The Virginia Department of Transportation (VDOT) built its Nimmo Parkway bridge using CFCC in precast concrete piles—the first CFCC bridge pile application in the world.

In addition to its application in replacing bridges, CFRP has been used to strengthen bridges. In Louisiana, 17.2 mm (0.7 in.) diameter CFCC has been used as external cable for the repair of the east girder of the Interstate 10 bridge in New Orleans. In addition, CFCCs were partially used in the cables of the cable-stayed Penobscot Narrows Bridge in Maine.

The following CFCC projects are planned for 2016:

- CFCC will be used for Michigan highways M 100 and M 86.
- The Ohio Department of Transportation will build its first CFCC prestressed side-by-side box-beam bridge.
- The FDOT Halls River bridge project will use CFCC as prestressing strand for precast concrete piles and precast concrete sheet piles.
- The Louisiana Department of Transportation and Development plans to use CFCC as prestressing strand for precast concrete piles.

Due to the lack of statewide or nationally accepted American Association of State Highway and Transportation Officials (AASHTO) design specifications, drafts of CFRP guide speci-

fications for the Michigan Department of Transportation (MDOT) and AASHTO NCHRP (National Cooperative Highway Research Program) 12-97 have been under development by researchers. These design specifications will help highway transportation agencies make decisions about the use of CFRP for prestressed concrete bridge beams.

## Characteristics of CFCC and anchorage systems

In addition to its noncorrosive nature, CFCC is characterized by its light weight and high tensile strength. The light weight enhances the workability and ease of handling of the materials.

CFCC does not exhibit any yield phenomena. Its stress-strain relationship is linear to failure. The elastic modulus is less than that of steel strands, so the materials will reach larger strains at comparable loading, thus experiencing larger deflections and pseudoductility. This unique performance influences the design requirements of members with CFCC reinforcement.

The anchorage system is a challenge when using CFCC in the field. Conventional anchoring devices that are used for steel strands are not suitable for CFCC because they damage the surface of CFCC and cause premature failure at the anchorage portion. Therefore, a new anchoring system needed to be developed. There are two types of anchorage systems currently available. The first anchorage system is composed of a threaded steel socket-and-nut system that is connected to the CFCC

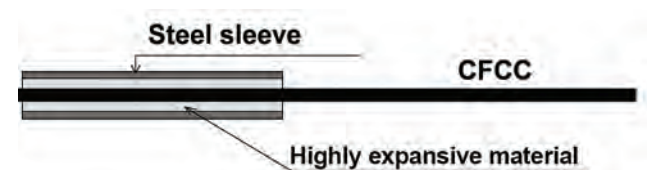

Anchorage system of posttensioning. Note: CFCC = carbon-fiber-composite cable.



Terminal fixer.

Properties of CFCC compared with steel strands of similar diameter		
Property	CFCC	Grade 270 steel strands
Diameter, in.	0.6	0.6
Effective cross-sectional area, in. <sup>2</sup>	0.179	0.217
Density, lb/ft	0.149	0.737
Ultimate tensile strength (minimum), ksi	339	270
Modulus of elasticity, ksi	22,400	29,000
Elongation at break, %	1.5	3.5 (minimum)
Note: CFCC = carbon-fiber-composite cable. 1 in. = 25.4 mm; 1 in. <sup>2</sup> = 645.2 mm <sup>2</sup> ; 1 lb/ft = 0.01459 kN/m; 1 ksi = 6.895 MPa; Grade 270 = 1860 MPa.		

## Anchoring system for pre-tension

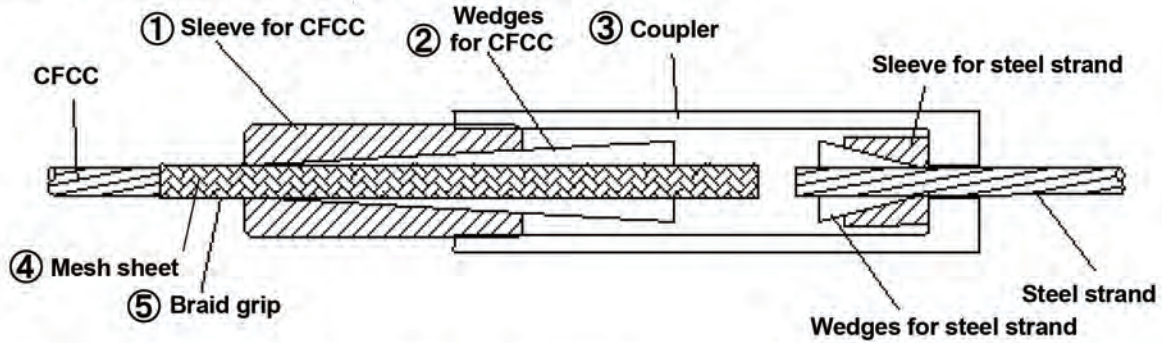

① Sleeve for CFCC



② Wedges for CFCC



③ Coupler



④ Mesh sheet



⑤ Braid grip



Anchorage system of pretensioning. Note: CFCC = carbon-fiber-composite cable.

using highly expansive material. This system is recommended for posttensioning applications.

The other anchorage system is a steel wedge-sleeve system. This system is developed for pretensioning applications. Buffer materials are wrapped around the strands to improve

the anchorage efficiency and avoid slippage of the CFCC. This system can further be employed in a joint coupler that is used to connect CFCC to steel strands. The joint coupler has been considered and developed to allow the tensioning of the CFCC by pulling steel strands so that precasters can utilize the conventional pretensioning procedure and equipment.

### CFCC projects

Project	State	Year	Application
Pembroke bridge over Southfield Freeway	Michigan	2011	Beam/posttensioned
M 102 bridges over Plum Creek, Southfield	Michigan	2013/14	Beam/pretensioned
Interstate 94 bridges over Lapeer Road, Port Huron	Michigan	2014/15	Beam/posttensioned
Kittery overpass bridge over State Route 234	Maine	2014	Beam/pretensioned
Nimmo Parkway bridge	Virginia	2014	Precast concrete pile/pretensioned
Route 49 bridge over Aaron's Creek	Virginia	2015	Beam/pretensioned
KY 70 bridge over Stoner Creek, Taylor County	Kentucky	2014	Beam/pretensioned
Innovation Bridge at University of Miami	Florida	2016	Beam/pretensioned

Note: CFCC = carbon-fiber-composite cable.

## Deployment of CFCC in the field

Details of the CFCC projects mentioned are explained in the following sections.

### **Pembroke bridge over Southfield Freeway, Detroit, Mich. (2011)**

MDOT built the Pembroke bridge to replace a deteriorated steel bridge over Southfield Highway M 39 in Detroit. The two-span bridge is 32.51 m (106.7 ft) long. Each span comprises 16 box beams with 150 mm (6.0 in.) composite deck. Each beam is 686 mm (27.0 in.) deep and 1220 mm (48.0 in.) wide and is prestressed with low-relaxation steel strands. Each span has six transverse diaphragms. One 37-wire 40 mm (1.6 in.) diameter CFCC was used for transverse posttensioning to integrate the adjacent box beams.

Traditional steel posttensioning tendons would require grouting of the ducts for corrosion protection. Due to the noncorrosive nature of CFCC, the ducts did not need to be grouted, which has advantages. If the cable stress needs to be adjusted during the service life of the structure or if a beam is damaged by a high load impact and needs to be replaced, the cables can be destressed for the adjustment or replacement work. CFCC was passed through a 150 mm (6.0 in.) diameter conduit and tensioned with a force of 685 kN (154 kip) at each diaphragm, corresponding to 57% of the 1200 kN (270 kip) breaking load. The anchorage devices were installed on the CFCC at the factory using 520 mm (20.5 in.) long threaded stainless steel sockets and expansive grout. After tensioning, the force in each CFCC was secured using a threaded stainless steel lock nut. Load cells were attached to the dead end of each CFCC to monitor the force level during construction and in service. The bridge was opened to traffic in December 2011. The moni-



End of transverse posttensioning strand for the Pembroke bridge in Michigan.



Completion of the Pembroke bridge over Southfield Freeway in Michigan.

toring system started in January 2012 and will continue until September 2020.

### **M 102 bridges over Plum Creek, Southfield, Mich. (2013 and 2014)**

MDOT replaced an existing earth-filled arch culvert on M 102 (8 Mile Road) with a CFCC prestressed spread box-beam structure. M 102 is a major urban route in the Detroit metropolitan area with four lanes of traffic in each direction. CFCC was thoroughly applied for the new precast concrete bridge as noncorrosive tendons, stirrups, and reinforcing bars. Each bridge was constructed with a skew angle of 45 degrees, a span of 20.7 m (67.9 ft), and a deck width of 18.8 m (61.7 ft). Each bridge superstructure comprises eight spread box beams supporting a 230 mm (9.1 in.) thick reinforced concrete deck slab. Each box beam has a width of 1220 mm (48.0 in.) and a depth of 840 mm (33 in.) and is prestressed by a total of 37 CFCC 15.2 mm (0.6 in.) diameter prestressing strands with an initial prestressing force of 146 kN (32.8 kip) per strand. The constructed beams were shipped to the site, and after the



Placing carbon-fiber-composite cable reinforcements in the deck of the M 102 bridges over Plum Creek in Michigan.



Prestressing bed with carbon-fiber-composite cable from the M102 bridges over Plum Creek in Michigan.

beams were placed the crew fabricated the formwork for the deck slab, which was also reinforced with two lattices of CFCC reinforcement.

### Interstate 94 bridges over Lapeer Road, Port Huron, Mich. (2014 and 2015)

Two side-by-side box-beam bridges were constructed to carry the east- and westbound Interstate 94 over Lapeer Road in Port Huron, Mich. The eastbound and westbound bridges were completed in 2014 and 2015, respectively. Each bridge consists of three spans with total length of 50 m (164 ft). The eastbound bridge, with a width of 17.6 m (57.7 ft), is composed of 14 beams and is posttensioned using 20 CFCCs with a 40 mm (1.6 in.) diameter and a transverse posttensioning force of 623 kN (140 kip) per diaphragm. The westbound bridge, with a width of 18.8 m (61.7 ft), comprises 15 beams and is posttensioned using 20 CFCCs with a 40 mm diameter and transverse posttensioning force of 667 kN (150 kip) per diaphragm. The box beams in both bridges have a depth of 840 mm (33 in.) and a width of 1220 mm (48.0 in.).



Passing carbon-fiber-composite cable strand through conduit for the Interstate 94 bridges over Lapeer Road in Michigan.



Completion of the eastbound Interstate 94 bridge over Lapeer Road in Port Huron, Mich.

### Kittery overpass bridge over State Route 234, Maine (2014)

After the successful deployment of CFCC in Little Pond Bridge, where CFCC was used as transverse posttensioning cables, Maine Department of Transportation (MaineDOT) built its first precast, prestressed CFCC bridge in 2014.



Installation of anchoring devices for the Kittery overpass bridge in Maine.

This 19.2 m (63.0 ft) simply supported bridge comprises eight precast concrete double-tee beams, called north-east extreme tee (NEXT) beams. Each beam has a deck width of 2655 mm (104.5 in.), depth of 915 mm (36.0 in.), and span of 18.9 m (62.0 ft). Each beam was prestressed with 40 CFCCs with a diameter of 15.2 mm (0.6 in.). The initial jacking force was 176 kN (39.5 kip) per strand.



Completion of northeast extreme tee beam for the Kittery overpass bridge in Maine.

### Nimmo Parkway bridge, Virginia (2014)

In Virginia, to mitigate the problem of corrosion, CFCC was used in the prestressed concrete piles of a bridge near the Atlantic coast. This particular bridge, on the Nimmo Parkway in Virginia Beach, had 18 prestressed piles—out of 272 total—constructed using CFCC. The Nimmo Parkway bridge is 457.2 m (1500 ft) long and traverses West Neck Creek and adjacent wetlands. The new bridge, near the Virginia Beach Municipal Center, is wider than the original to reduce urban traffic congestion and improve safety for bicyclists and pedestrians. It is expected that the use of CFCC will be beneficial to mitigate corrosion and help reduce the maintenance costs required in this particular marine environment.



Completed precast concrete piles for the Nimmo Parkway bridge in Virginia.

### Route 49 bridge over Aaron's Creek, Virginia (2015)

VDOT built its first bridge with CFRP reinforcement in 2014. This is a two-span bridge with a total deck width of 9.85 m (32.3 ft). Each span has a length of 25.46 m (83.53 ft). The span comprises four 1143 mm (3.75 ft) deep bulb-tee girders. Each bulb-tee girder was prestressed with forty-four 15.2 mm (0.6 in.) diameter CFCCs. Each strand was prestressed with an initial prestressing force of 147 kN (33 kip). The stirrups were also made of CFCC and had 15.2 mm (0.6 in.) and 17.2 mm (0.68 in.) diameter.



Prestressing bed with carbon-fiber-composite cable strands/spirals for piles for the Nimmo Parkway bridge in Virginia.



Driving test of the precast concrete pile for the Nimmo Parkway bridge in Virginia.

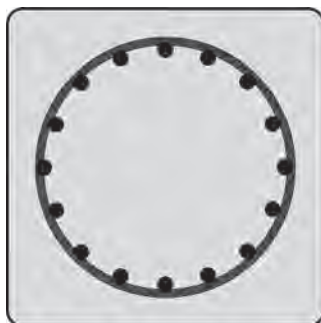

610 mm square pile  
16 strands of CFCC  
15.2 mm seven-wire strand  
Spiral CFCC 5.7 mm single-wire strand

Pile. Note: CFCC = carbon-fiber-composite cable. 1 in. = 25.4 mm.

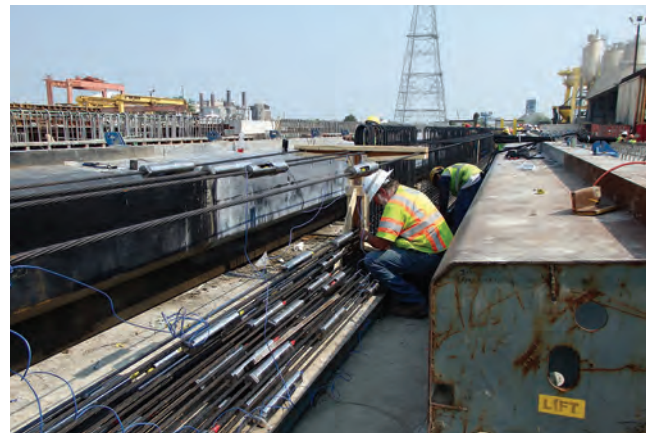

Preparation for setting stirrups for the Route 49 bridge in Virginia.



Removing beams from forms for the Route 49 bridge in Virginia.

### KY 70 bridge over Stoner Creek, Taylor County, Ky. (2014)

A new hybrid I-girder bridge was built to replace a functionally obsolete bridge on KY 70 over Stoner Creek in Taylor County. The two-span, reinforced concrete deck girder bridge and center pier were replaced with a single-span hybrid I-girder bridge. This is the first time that CFCC pretensioned beams were used by the Kentucky Transportation Cabinet. The use of precast concrete beams could lessen congestion associated with



Staggering of anchoring devices for the KY 70 bridge in Kentucky.



Fabrication of the beam for the KY 70 bridge in Kentucky.

construction and increase the safety of accelerated bridge construction methods. The use of CFCC and stainless steel reinforcement in place of the traditional corrosion-prone steel tendons and reinforcement, will increase the expected service life of the bridge. The bridge is 23.33 m (76.54 ft) long and 8.3 m (27 ft) wide. The bridge has six beams, which are 1016 mm (3.33 ft) deep and 1370 mm (4.5 ft) wide. Each beam was prestressed with twenty-nine 15.2 mm (0.6 in.) diameter CFCCs with a load of 55% of its guaranteed capacity.

### Innovation Bridge at the University of Miami, Coral Gables, Fla. (2015)

At the University of Miami's Coral Gables campus, a pedestrian bridge, called the Innovation Bridge, was built with the intention of ensuring a 75-year service life. The bridge has a 21 m (70 ft) long single span and used only composite materials, without a single pound of mild steel in any element of the bridge. The two precast concrete girders were in the shape of double-tee beams, which are typically used for parking structures. Each girder is 762 mm (2.5 ft) deep and 2171 mm (7.12 ft) wide. Each girder stem was prestressed with nine 15.2 mm (0.6 in.) diameter CFCCs. Each strand was tensioned to a load of 180 kN (41 kip), corresponding to approximately 70% of its guaranteed capacity.



Carbon-fiber-composite cable strands in the stem for the Innovation Bridge in Florida.



Completion of double-tee beam for the Innovation Bridge in Florida.



## Acknowledgments

The authors appreciate the support and assistance provided by Nabil Grace, Distinguished Professor at Lawrence Technological University in Southfield, Mich.; Matthew Chynoweth, deputy metro region engineer for MDOT; Wayne Frankhauser, bridge program manager for MaineDOT; Celik Ozyildirim, principal research scientist for VDOT; Issam Harik, professor at the University of Kentucky in Lexington; and Antonio Nanni, professor at the University of Miami.

The authors also acknowledge the assistance provided by Aiko Shirakawa of Tokyo Rope Manufacturing Co. Ltd.'s CFCC division.



### About the authors



Kenichi Ushijima is plant manager for Tokyo Rope USA Inc.



Tsuyoshi Enomoto, PhD, is a sales engineer and vice president for Tokyo Rope USA Inc.



Noriaki Kose is manager of the carbon-fiber-composite cable division of Tokyo Rope Manufacturing Co. Ltd.



Yoshiaki Yamamoto is president and CEO of Tokyo Rope USA Inc. and deputy general manager of the carbon-fiber-composite cable division of Tokyo Rope Manufacturing Co. Ltd.

### Abstract

Carbon-fiber-reinforced polymer (CFRP) materials are an alternative to steel reinforcement and prestressing strands in harsh climates because of their noncorrosive nature, durability, high tensile strength, and light weight. This paper discusses the use of CFRP in bridges in the form of carbon-fiber-composite cable (CFCC). CFCC's unique performance influences the design requirements of members with CFCC reinforcement. The American Association of State Highway and Transportation Officials and Michigan Department of Transportation are developing guidelines that will help highway transportation agencies make decisions about the use of CFRP for prestressed concrete bridge beams.

### Keywords

Anchorage, bridge, carbon-fiber-composite cable, carbon-fiber-reinforced polymer, CFCC, CFRP, coast, corrosion, durability, girder, prestressing, reinforcement, steel.

### Reader comments

Please address reader comments to [journal@pci.org](mailto:journal@pci.org) or Precast/Prestressed Concrete Institute, c/o *PCI Journal*, 200 W. Adams St., Suite 2100, Chicago, IL 60606. 



# TOKYO ROPE USA, INC.

A Tokyo Rope company



TOKYO ROPE MFG. CO., LTD.

ESTABLISHED IN 1887

# CFCC

## Carbon Fiber Composite Cable

- High tensile strength
- High tensile modulus
- Lightweight
- High corrosion resistance
- Non magnetic interact
- Low linear expansion
- Flexibility

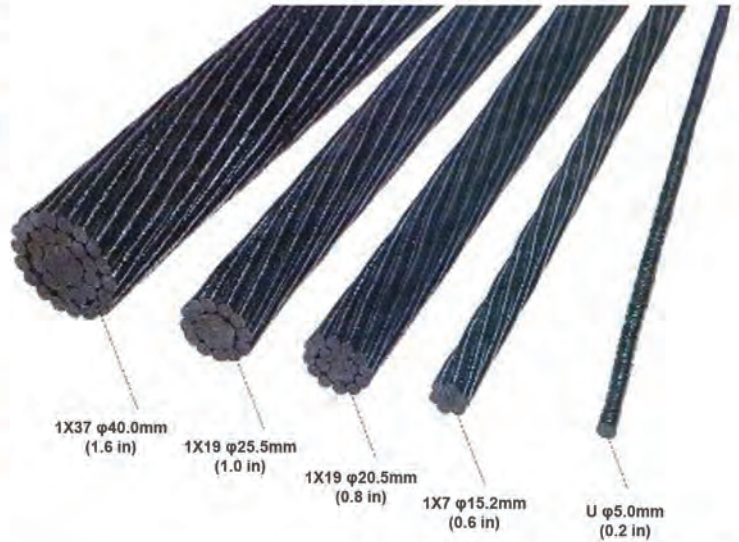

### Lightweight

Due to its lightweight (about one-fifth of steel strands), CFCC elements have a specific gravity of 1.5.



15m → 3.32kg  
 (49ft 2.55in → 7.32lb)  
 1X7  $\phi$ 15.2mm (0.6in)



CFCC 1X7  $\phi$ 15.2mm (0.6in)  
 (Pre-tensioning)



CFCC 1X37  $\phi$ 40.0mm (1.6in)  
 (Post-tensioning)

### Flexibility

The stranded design of cable allows easy coiling or reeling onto the drum.



Spool of CFCC reeled onto the drum with shell diameter 1.55m (5ft 1in)  
 1X7  $\phi$ 15.2mm (0.6in)  
 1170m (3838ft 6.9in)



Terminal fixer for pre-tensioning



Terminal fixer for post-tensioning



Stirrup



## TOKYO ROPE USA, INC.

8301 Ronda Drive, Canton, MI 48187

Phone: 734-335-6037 Fax: 734-335-6576 [www.tokyorope.co.jp/english/product/cfcc](http://www.tokyorope.co.jp/english/product/cfcc)